

2021
EMEA

ENGLISH

ACRYLIC SOLID SURFACE

WIDE MATERIAL
FOR WIDE IDEAS



FIFTY YEARS

AVONITE®

**WIDE AND
FLEXIBLE.
THE SOLUTION
TO ACCOMPLISH
YOUR BOLDEST
PROJECTS.**

AVONITE® is a solid surface material composed of 63% alumina trihydrate, 35% acrylic and 2% pigments and binders. It is produced at the Aristech Surfaces LLC plant, in Florence (KY), USA, one of the most flexible and scalable production lines in the world. Aristech Surfaces LLC relies on its experience and expertise to supply a reliable Solid Surface material.

COLOURFUL

Complimented by a range of colours specially selected to serve the European market, AVONITE® offers tones and textures suited to the creation of harmonious spaces. Homogeneous throughout its thickness, the material allows for careful cutouts, as well as the sanding of its surface, capable of giving it a lusted sheen at all times.



THERMOFORMABLE

AVONITE® sheets become supple and malleable when exposed to the heat of special ovens. One thing is certain: with its organic shapes and rounded corners, the material's gentle curves provide comfort and warmth to any interior design.



TRANSLUCENT

Whether through the even and glossy translucence of Ice White or the creation of motifs trimmed in lighter colours, AVONITE® offers beautiful ways to treat light.



MONOLITHIC

AVONITE® adhesives are colour matched exactly to ensure seamless joints. Now you can create monolithic installations and counters stretching as far as the eye can see!



Private residence, Antwerp, Belgium, 2020
Design and fabrication: Del Duca Interieur
AVONITE® Summit 8905



ONE OF THE MOST ADVANCED PRODUCTION TECHNOLOGIES

The ability of our double belt production lines to create a multi-stage system, incorporating controlled heating, cooling and tempering – all within one press – enables the development of highly efficient processing solutions.

MORE DETAILS [PAGE 12](#)

RIGHT SIZE PROGRAMME

OUR STANDARD FORMATS

AVONITE®'s **RIGHT SIZE** Programme provides the ultimate in flexibility, saving time and labour costs.

MORE DETAILS [PAGE 14](#)



OUR COMMITMENT TO ECOLOGY

We see sustainability as more than just offering products with recycled content and regulatory compliance. It means having a responsibility to touch and improve lives by making a positive impact on others, now and for the future.

MORE DETAILS [PAGE 16](#)

Stand Aristech Surfaces, Euroshop 2020, Düsseldorf, Germany, 2020

Design: Lucchesedesign

Fabrication: LCCA

Photo: Dumitru Brinzan

AVONITE® Azul 8284,
Café au Lait 8272,
Eclipse 8240,
Fuego 8248,
Mango 8268,
Smoke 8280,
Snowfall 8090





The Catalyst: national data innovation hub, Newcastle, UK, 2019
 Design, fabrication and installation: Raskl. Art + Architectural Production
 Exterior rendering specialist: Chemplas
 Photos: Jack Storey
AVONITE® Snowfall 8090

Using AVONITE® as a cladding on the entry façade of this building enabled the reconciliation of design-related mechanical restrictions and the installation of a lighting system. The machined Solid Surface panels were mounted on a custom metal frame and attached using threaded inserts.



EXTERIOR

A NETWORK OF EXPERTS

We have a network of Solid Surface experts experienced in building facades, using our ETA certified AVONITE®, which you can aspire to use on the most ambitious projects.

The **RIGHT SIZE** Programme also offers a competitive product portfolio that is perfectly suited to the creation of exterior façades.

For outdoor use, AVONITE® recommends 7 colours (see p. 18), for which we predict a UV resistance under $\Delta E 5$ and gloss loss of less than 40% for a matt finish.

Casa-Voyageurs train station, Casablanca, Morocco, 2019

Architecture: Yassir Khalil Studio

Fabrication: Aeria 2

Photo: alessiomei.com

AVONITE® Snowfall 8090

With over 25 000 sq. metres of Solid Surface, the new Casablanca train station is currently one of the industry's biggest construction sites in the world. Fully entrusted to AVONITE®, this project involves cladding the building's entire roof, façade and ceiling.



Shopping City Satu Mare,
Romania, 2018

Design, fabrication and photos:
Atvanguard

AVONITE® Snowfall 8090,
Smoke 8280,
Cardamom 8286*,
Dove Grey 8231

AVONITE® was selected as the cladding for window boxes, bench seats, recycling bins, signs and digital pillars sprinkled around this 29000 sq. metre shopping centre, and as the cladding for the massive 8-metre long triangular reception desk welcoming visitors as they enter the building.



COMMERCIAL

AVONITE® IS ABSOLUTELY VERSATILE

It can be found on both the countertops and walls of ultra-clean labs and the overworked reception desks at hotels.

THAT'S NOT ALL

AVONITE® is also used to produce flawless furniture for shops and museums.



HYGIENIC

The material's non-porous properties and the seamless assembly of furniture made of AVONITE® makes it extremely easy to clean. Its thermoforming capacity also allows for the creation of rounded backsplashes on lab benches, kitchen counters and restaurant furniture, which eliminates those hard to reach places.



DURABLE

AVONITE® is resistant to common household products and is easy to repair, thanks to the after sale servicing by one of our local partners. With its 15-year warranty on 12, 9 and 6 mm thicknesses and 10 year-warranty on the 3 mm thickness, AVONITE® will not fail you after your project is complete.



15
YEAR
WARRANTY

*This colour is no longer offered in the standard AVONITE® range but can be ordered, subject to a minimum order quantity and longer delivery time.



Private residence, Pfungstadt, Germany, 2020
 Fabrication: Rosskopf + Partner AG
 Photo: edelfotoGrafie! / Böhm Küchen
AVONITE® Porcelain 8066

A 100% AVONITE® look in this kitchen, featuring a worktop fitted with a seamless Solid Surface sink and flush-mounted stove. 3 mm-thick AVONITE® sheets also cover all of the cupboard doors and drawers.

RESIDENTIAL

Used for kitchen islands, vanity tops and shower bases in bathrooms, or modern furnishings, AVONITE® fits harmoniously into private residences.



ADVANC3®
ARE YOU LOOKING FOR AN ALTERNATIVE TO LAMINATE AS A FURNITURE COVERING?

AVONITE® IS A GREAT SOLUTION!

With its sheets just 3 mm thick, AVONITE® ADVANC3® offers all the properties and aesthetics of a Solid Surface at unbeatable prices. ADVANC3® can only be used on installations with no heat source at proximity.

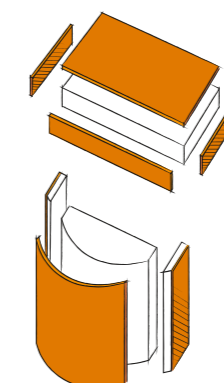

ADVANC3®



ONE OF THE MOST ADVANCED PRODUCTION TECHNOLOGIES

THE ABILITY OF OUR DOUBLE BELT PRODUCTION LINES TO CREATE A MULTI-STAGE SYSTEM, INCORPORATING CONTROLLED HEATING, COOLING AND TEMPERING – ALL WITHIN ONE PRESS – ENABLES THE DEVELOPMENT OF HIGHLY EFFICIENT PROCESSING SOLUTIONS.

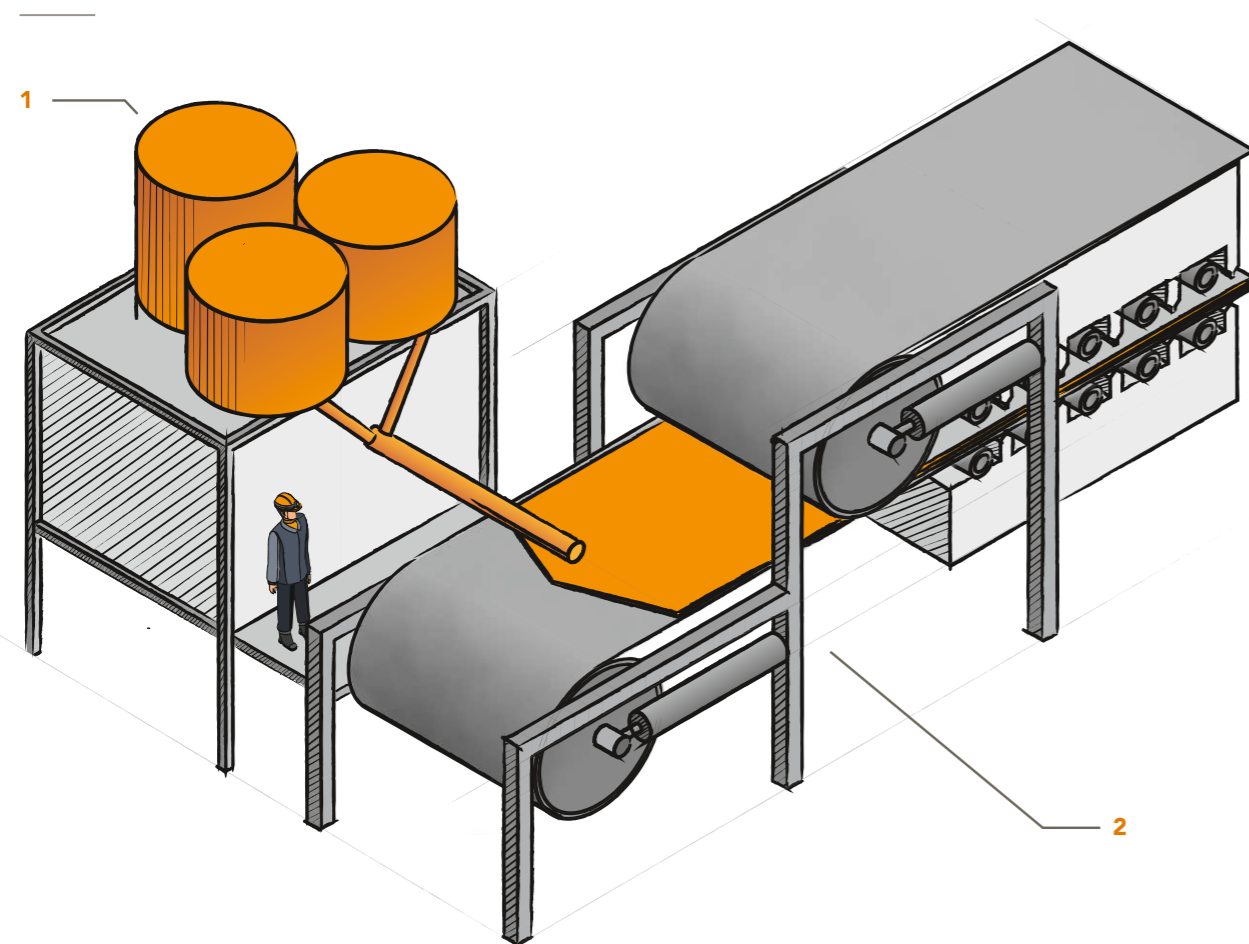

1 The manufacturing process begins with mixing of the constituent materials (Methyl Methacrylate, solution of pre-polymerised methyl methacrylate, Alumina Trihydrate, pigments, catalysts, and chips, if needed) in a batch vessel. The use of a batch vessel for mixing all the ingredients ensures that a well-mixed homogeneous mixture is delivered to the double-belt continuous cast process.

2 The compound product is then cast between the belts. Through the application of heat and pressure, the product is pressed, calibrated and cooled down under pressure. This system enables very high pressure to be delivered uniformly.

Often associated with a continuous cast production line, a double belt press typically includes top and bottom belts with heating elements and pressure mechanisms that transfer heat and pressure to the products between the belts. One of the major advantages to this machine is its ability to continuously hold product under heat for and cool to set good strength. Product is held securely throughout complete process.

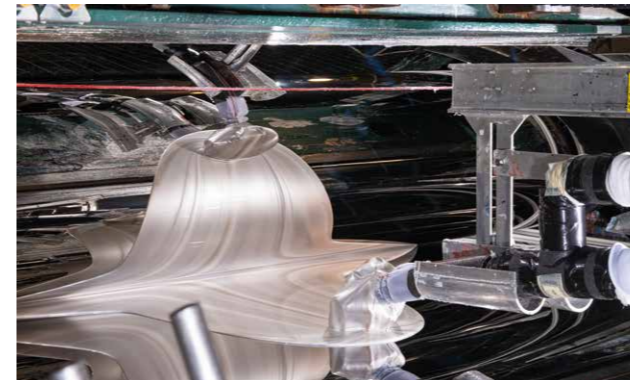

BENEFITS OF OUR TECHNOLOGY

VERSATILE ADJUSTABLE PRODUCT WIDTH

The use of a double-belt continuous cast process allows the adjustment of the product width to any size between 686 mm and 1524 mm. Thanks to this highly efficient process, Aristech Surfaces LLC offers 3 different widths at no surcharge cost per m² and any other width between 686 mm and 1524 mm at a highly competitive price.

IMPECCABLE COLOUR CONSISTENCY

Continuous-casting optimises the mixing of ingredients to offer a perfect colour consistency not only within the same batch but even within different production batches ($\Delta E < 1$).

NARROW THICKNESS TOLERANCE

The thickness of the product – taking into account the shrinking effect – is easily adjusted by means of a high precision gear and spindle system that sets the gap between upper and lower belt. Consequence? AVONITE®'s tolerance on the thickness across a sheet is the lowest among any other Acrylic Solid Surface. Precision in manufacturing is key for the most ambitious projects and AVONITE® is meant to be part of them.

ECO-FRIENDLY MANUFACTURING

Realised without solvent and from a 100% monomer solution, the bulk polymerization of methyl methacrylate produced in the double-belt manufacturing process contributes to reduce the impact of Volatile Organic Compounds on environment. That's how AVONITE® has been classified by SCS Global Services at the most demanding level "Indoor Advantage Gold" for its capacity to preserve indoor air quality. And that's not all: with its symmetric heating and cooling system, this highly efficient system contributes to save energy. Finally, continuous-casting improves the yield and reduces scrap for an optimised usage of resources.



OUR RIGHT SIZE PROGRAMME



THE ULTIMATE FLEXIBILITY

You can customize your sheets to your specific needs, **by thickness, width, length and in any standard colour***. From the simplest format to the most unusual designs, Aristech Surfaces LLC offers you an infinitely wide array of options.

SAVES TIME

The use of large sheets reduces the number of seams required. Fewer seams mean less adhesive, less fabrication and therefore less cost.

SUSTAINABLE CHOICE

The choice of an optimal size sheet simply reduces scrap. Less scrap means taking a step to help the environment.

* The RIGHT SIZE Programme applies to any standard AVONITE® colour, with the exception of Ice White 8064, Ice Blue 8298, Altitude 8901, Torrent 8903, Morning Mist 8904, Summit 8905, Calm 8908 and Unwind 8909. Please contact your regional sales manager or local distributor for more information, on lead times and minimum orders.



Freiberg Visitor Centre, Germany, 2018
 Architecture: Atelier n.4
 Fabrication: Rosskopf + Partner AG
 Photo: Albrecht Holländer
AVONITE® Eclipse 8240
Polaris 8256



2 134 x 686 mm
 SHEETS' MINIMUM DIMENSIONS

THICKNESS

- 3 mm
- 6 mm
- 9 mm
- 12 mm
- 19 mm

5 182 x 1 524 mm
 SHEETS' MAXIMUM DIMENSIONS





OUR COMMITMENT TO ECOLOGY

WE SEE SUSTAINABILITY AS MORE THAN JUST OFFERING PRODUCTS WITH RECYCLED CONTENT AND REGULATORY COMPLIANCE – IT MEANS HAVING A RESPONSIBILITY TO TOUCH AND IMPROVE LIVES BY MAKING A POSITIVE IMPACT ON OTHERS, NOW AND FOR THE FUTURE.

REUSE AND RECYCLE

At Aristech Surfaces LLC, we continually strive to improve our energy and water efficiency, landfill diversion, and air quality, using performance metrics we measure and report. Recent and ongoing environmental initiatives include conversion to LED lighting at our plants and offices, proactive recycling of office and industrial materials, high-efficiency motor upgrades to machine drives, industrial water filtration and recycling systems and thermal oxidizing units with heat recovery to reduce VOC emissions.

Finally, Aristech Surfaces LLC transport partner for Europe guarantees recycling of waste water, uses solar energy in the warehouse and trucks that run on gas.

INDOOR ENVIRONMENTAL QUALITY

AVONITE® has been awarded Indoor Advantage Gold by SCS Global Services and earned a score of A+ for the material's adherence to French regulations governing the emission of volatile organic compounds.

REDUCING WASTE

The **RIGHT SIZE** Programme is another key component of our approach to sustainable design. The possibility of choosing the best format for your projects optimizes the material consumption to suit your needs.

ENERGY CONSERVATION

Historically, it's not a coincidence if we chose to work with a double-belt continuous cast technology. Equipped with a symmetric heating and cooling system, solvent free and allowing to reduce the waste to the lowest level, this manufacturing technique is one of the eco-friendliest.

Our recent efforts to conserve energy include updating boiler controls and eliminating an inert gas generator at our Belen, New Mexico facility; installing a new nitrogen system, which improved energy efficiency and reduced emissions. Our Florence, Kentucky site was re-lamped with LED technology, significantly reducing electrical consumption.

TRANSPARENCY AND DISCLOSURE

Expectations of transparency about the environmental and health impacts of building products are high in the green building market. Designers, specifiers and building owners want to know exactly what they are utilizing, encouraging the specification of products with documented declaration of contents and impacts. Aristech Surfaces LLC provides transparency documentation through EPDs, HPDs, and soon, Declare Labels.

RED LIST FREE

AVONITE® solid surface is Living Building Challenge Red List Free, containing none of the 800+ hazardous chemicals found in some building products.

Certified leader:



OUR COLOUR SELECTION

Whether the simple elegance of Altitude, the depth of the Summit, the inimitable texture of Sandstorm, the purity of Ice White or the vitality of Mango, AVONITE® offers a colour range balanced between the latest trends and timeless classics.

Depending on the climate, the orientation and the application, AVONITE® recommends 7 colours for outdoor use (highlighted with a Δ hereunder). We predict a UV resistance under ΔE 5 and a gloss loss of less than 40% for a matt finish.

PRICE GROUP 0 Δ 8090 Snowfall

PRICE GROUP 1 Δ 8256 Polaris 8066 Porcelain 8026 Super White 8016 White 8106 Ivory 8024 Crème 8010 Bone

PRICE GROUP 2 8292 Cloud 8231 Dove Grey D 8280 Smoke D 8272 Café au Lait D 8268 Mango 8258 Antique Blue D 8284 Azul D 8248 Fuego

PRICE GROUP 4 8206 Alpine Shimmer 7749 Mellow 7817 Harland 7856 Dove Shimmer D 7830 Bronze D 7820 Star Shine D 9024 Night Shadow

PRICE GROUP 5 7848 Snow Mist 9173 Riverside 9017 Savor 7790 Galactic Ice 9119 Nordic 9012 Aspen 4310 Coastline 7842 New Concrete 9010 Stormy Gray

4312 Alaskan Stone D 7849 Industrial 9117 Kokoura 9015 Artica 7810 Malt 9036 Sandstorm 9037 High Desert 7857 Vintage Concrete D 7738 Storm

ENRICHED COLOUR TECHNOLOGY

Aristech Surfaces LLC has created a new and innovative AVONITE® formulation: Enriched Colour Technology. This product delivers more intense colour and its improved mechanical properties make it more scratch resistant*. Enriched Colour Technology is available in the Eclipse colour.

* The colours produced with this technology are still more delicate than less pigmented colours and remain a D-category product.

Private residence, Belgium, 2020
Design and fabrication: Denis Margot
AVONITE® Eclipse 8240



OUR BUZZWORD IS FLEXIBILITY. IN JUST TWO WEEKS, WE WILL SEND YOU A SAMPLE, INFORMATION ON THE MINIMUM ORDER QUANTITY AND A QUOTE FOR YOUR PERSONALISED CUSTOM COLOUR. WORKING WITH US IS AS SIMPLE AS THAT.

PRICE GROUP 3 8064 Ice White 8298 Ice Blue D 8240 Eclipse

HAVE A PROJECT IN PROGRESS?

Request the free colour samples of your choice on www.aristechsurfaces.com/avonite or ask for a visit from an AVONITE® expert.

PRICE GROUP 6 7728 Relic 7502 Avalanche 7501 Moon Crystal 7746 Cloud Burst D 9125 Black Coral 7509 Seaside 7724 Creek Rock 7747 Stony Peak 9137 Casablanca

4330 Honey Crunch 7710 Gulf Coast 9144 Palermo 7503 Morning Tundra 7506 River's Edge D 7735 Dark Roast

PRICE GROUP 7 8908 Calm 8901 Altitude 8909 Unwind 8904 Morning Mist 8905 Summit 8903 Torrent

The tones shown on this page may differ slightly from the actual colours. To be safe, make your choice based on samples.

Δ Recommended colours for outdoor use.

D These décors are heavily pigmented colours, and are prone to show scratches, dust, haziness, and ordinary wear and tear more easily than lighter textured décors. Therefore, these décors are not recommended for use in residential and commercial applications that will be subject to heavy use, and/or horizontal application use, and will not be covered under the AVONITE® warranty in relation to claims for scratches of ordinary wear and tear.

♻️ Contains Recycled Content Colours marked with this acronym include recycled material and may therefore qualify for additional credits as part of the building's LEED accreditation.



TECHNICAL INFORMATION

THAT'S NOT ALL... SHEET DIMENSIONS

AVONITE®'s **RIGHT SIZE** Programme provides the ultimate in flexibility, saving time and labor costs.

AVONITE®'s flexibility is based on the 5 formats of sheets that we keep in stock at our European depot.

THICKNESS (mm)	DIMENSIONS (mm)	AVAILABLE COLOURS
6	W. 762 x L. 3 658	8090 Snowfall
9	W. 762 x L. 3 658	8090 Snowfall
12	W. 762 x L. 3 658	All colours*
	W. 914 x L. 3 658	8901 Altitude 8903 Torrent 8904 Morning Mist 8905 Summit 8908 Calm 8909 Unwind
	W. 1 372 x L. 3 658	8064 Ice White 8298 Ice Blue 8090 Snowfall 8256 Polaris
	W. 1 524 x L. 3 658	8090 Snowfall

To receive a list of our formats and our terms of sale, or for any additional information, please contact us on

WWW.ARISTECHSURFACES.COM/AVONITE

*With the exception of 8064 Ice White, 8298 Ice Blue, 8901 Altitude, 8903 Torrent, 8904 Morning Mist, 8905 Summit, 8908 Calm and 8909 Unwind.

Der Storchwirt Museum, Neustadt an der Donau, Germany, 2020

Planner: Framegrabber Medien GmbH, Tim Mugele

Fabricator: Roskopf + Partner AG

Photo: Fotografie Sedlmayer

AVONITE® Snowfall 8090, Vintage Concrete 7857, Ice White 8064



CHEMICAL DATASHEET

To determine stain and chemical resistance, chemical reagents are placed on the surface for 16 hours*. After the 16 hours period, reagents are removed using the cleaning methods described in the Technical Bulletin 201 (ISFA 2-01 and ANSI/ICPA SS-1 standards).

STAIN RESISTANCE

Stain resistance looks at the effect below the surface. The following reagents show no lasting effects on the surface of AVONITE® sheets when tested to the ISFA 2-01 cleanability/stain resistance standard:

- Acetic Acid (10%)
- Acetone
- B-4 Body Conditioner
- Ball Point Ink Pen
- Black Paste Shoe Polish
- Bleach (Household Type)
- Butyl Acetate
- Butyl Alcohol
- Butyl Ether
- Catsup
- Citric Acid (10%)
- Cupra Ammonia
- Dishwasher Detergent (Cascade)
- Dishwashing Liquid
- Distilled Water
- Ethanol
- Ethyl Alcohol (90%)
- Finger Nail Polish Remover
- Gasoline
- Household bleach
- Household Ammonia
- Hydrogen Peroxide
- Hydrogen Peroxide Solution, 3%
- Instant Coff
- Isopropyl Alcohol (90%)
- Lemon Juice
- Lye Solution (1-2%)
- Mercurochrome (2%)
- Methanol
- Methyl Acetate
- Methyl Ethyl Ketone
- Methyl Orange (1%)
- Methyl Red (1%)
- Mineral Oil
- Naphtha
- Olive Oil
- Pencil Lead
- Permanent Marker
- Pig Blood
- Pine Oil
- Povidone Iodine (10%)
- Yellow Mustard
- Sodium Sulfate (10%)
- Soy Sauce
- Sugar (sucrose)
- Toluene
- Tomato Juice
- Trisodium Phosphate (5%)
- Urea (6%)
- Vegetable Oil
- Vinegar
- Wax Crayon
- Wet Pekoe Tea Bag
- Wine
- Xylene
- Zinc Chloride (10%)

CHEMICAL RESISTANCE

Chemical resistance is a measure of visible surface changes. The following reagents show no lasting effects on the surface of AVONITE® Acrylic Solid Surface sheets when tested to the ANSI/ICPA SS-1 standard:

- Acetic Acid (10%)
- Acetone
- Acridine Orange
- AG Eosin Blue (5%)
- AG Gentian Violet
- Ammonia (10%)
- Ammonium Hydroxide (28%)
- Amyl Acetate
- Amyl Alcohol
- Aromatic Ammonia
- B-4 Body Conditioner
- Ball Point Pen
- Betadine Solution
- Bite Registration Accelerator (2% Eugenol)
- Bite Registration Base
- Black Paste Shoe Polish
- Bleach (Household Type)
- Blood
- Butyl Acetate
- Butyl Alcohol
- Butyl Ether
- Catsup
- Citric Acid (10%)
- Coffee
- Cupra Ammonia
- Dishwashing Liquid (Cascade)
- Dishwashing Liquid (Dawn)
- Distilled Water
- Equalizing Accelerator
- Ethanol
- Ethyl Acetate
- Ethyl Alcohol (90%)
- Nail Polish Remover
- Gasoline
- Hexane
- Household Soaps
- Hydrogen Peroxide
- Hydrogen Peroxide Solution (3%)
- Instant Coffee
- Isopropyl Alcohol (90%)
- Lemon Juice
- Lye Solution (1-2%)
- Mercurochrome (2%)
- Methanol
- Methyl Acetate
- Methyl Ethyl Ketone
- Methyl Orange (1%)
- Methyl Red (1%)
- Mineral Oil
- Naphtha
- Napthalene (Naphtha)
- Nitric Acid (6%)
- Olive Oil
- Pencil Lead
- Perchloric Acid
- Permanent Marker Ink
- Picric Acid
- Pig Blood
- Pine Oil
- Povidone Iodine (10%)
- Yellow Mustard
- Salt (Sodium Chloride)
- Silica Dental Cement (liquid)
- Silver Nitrate (10%)
- Soapless Detergents
- Sodium Bisulfate
- Sodium Hydroxide Solution (<10%)
- Sodium Hypochlorite (5%)
- Sodium Sulfate (10%)
- Soy Sauce
- Sugar (Sucrose)
- Tea
- Toluene
- Tomato Juice
- Trisodium Phosphate (5%)
- Urea (6%)
- Uric Acid
- Urine
- Vegetable Oil
- Vinegar
- Wax Crayon
- Wet Pekoe Tea Bag
- Wine
- Xylene
- Zinc Chloride (10%)

The following reagents should not come into contact with AVONITE® sheets for long periods of time. These reagents may cause surface changes on the sheets that are more difficult to remove:

- Bite Registration Mix (50/50)
- Dry-Bond Dental Adhesive
- Eosine Methylene Blue
- Hydrochloric Acid (>20%)
- Nail Polish
- Nitric Acid (>25%)
- Sodium Hydroxide Solution (>25%)
- Sulfuric Acid (>25%)

*Although the 16 hours period is standard test procedure, it is recommended to remove chemicals as soon as possible, to prevent damage to the surface.



PHYSICAL PROPERTIES

AVONITE® ACRYLIC SOLID SURFACING SHEETS

Aristech Surfaces LLC AVONITE® Acrylic Solid Surface “Specialty Blend Solid Surface” sheet products in a variety of attractive colors provide exceptionally weatherable, strong, non-porous, scratch and stain resistant material for architectural designs and utilitarian surfaces.

PROPERTY	TEST METHOD	UNITS	3 mm	6 mm	9 mm	12 mm				AVONITE® 8064 ICE WHITE 8298 ICE BLUE
			SOLIDS	SOLIDS	SOLIDS	SOLIDS	SMALL PARTICULATE	MEDIUM PARTICULATE	LARGE PARTICULATE	
GENERAL										
Density	ASTM D 792	g/cm³	1.73	1.73	1.73	1.73	1.60	1.62	1.63	1.60
Water Absorption	ASTM D 570	%	0.13	0.04	0.04	0.04	0.05	0.05	0.05	0.05
MECHANICAL										
Tensile strength	ASTM D 638	MPa	33.4	31.1	31.1	31.1	31.1	28.3	25.2	30.7
Tensile modulus	ASTM D 638	MPa	7010	10514	10514	10514	7142	8411	8204	8650
Tensile elongation	ASTM D 638	%	1.40	0.40	0.40	0.40	1.00	0.55	0.45	2.20
Flexural strength	ASTM D 790	MPa	71.0	64.1	64.1	64.1	55.2	49.3	47.2	58.3
Flexural modulus	ASTM D 790	MPa	6070	8687	8687	8687	7329	7240	8067	7010
Barcol hardness	ASTM D 2583	-	59	63	63	63	58	59	60	55
Rockwell hardness (m scale)	ASTM D 785	-	86	94	94	94	94	93	93	92
Charpy impact	ASTM D 6110	J/m	104.0	58.7	58.7	58.7	58.7	45.3	42.7	59.8
Ball impact (227g ball, no failure)	NEMA LD3-3.8	cm	-	-	305	>380	305	290	215	>380
Ball Impact (227g ball, no failure) Supported	NEMA LD3-3.8	cm	>380	>380	-	-	-	-	-	-
Ball Impact (227g ball, no failure) Unsupported	NEMA LD3-3.8	cm	213	215	-	-	-	-	-	-
THERMAL										
Dt _{ul} @ 1.82 Mpa	ASTM D 648	°C	88	102	102	102	93	93	92	100
Coefficient of thermal expansion	ASTM D 696	cm/cm/°C	-	3.76x10 ⁻⁵	3.76x10 ⁻⁵	3.76x10 ⁻⁵	4.43x10 ⁻⁵	4.43x10 ⁻⁵	4.43x10 ⁻⁵	-
Boiling water resistance	ISFA 2-01	-	No Effect	No Effect	No Effect	No effect	No effect	No effect	No effect	No effect
High temperature resistance	ISFA 2-01	-	No Effect	No Effect	No Effect	No effect	No effect	No effect	No effect	No effect
Reaction to fire	ASTM E 84	-	Class B	Class A	Class A	Class A	Class A	Class A	Class A	Class B
Combustion toxicity	Pittsburgh Protocol	-	98	98	98	98	67	67	67	98
Total Volatile Organic Compounds	ASTM D 5116	µg/m²/hr	69.1	69.1	69.1	69.1	69.1	69.1	69.1	69.1
SURFACE										
Consistency of colour (same sheet)	ISFA 2-01	-	Passes	Passes	Passes	Passes	Passes	Passes	Passes	Passes
Light resistance	ISFA 2-01	-	No Effect	No Effect	No Effect	No effect	No effect	No effect	No effect	No effect
Cleanability/Stain resistance	NEMA LD3-3.4	-	Passes	Passes	Passes	Passes	Passes	Passes	Passes	Passes
Stain resistance	ANZI/ICPA SS-1	-	Passes	Passes	Passes	Passes	Passes	Passes	Passes	Passes
Bacterial resistance	ASTM G 22	-	No growth	No growth	No growth	No growth	No growth	No growth	No growth	No growth
Fungi resistance	ASTM G 21	-	No growth	No growth	No growth	No growth	No growth	No growth	No growth	No growth
Food zone use	NSF 51	-	Approved	Approved	Approved	Approved	Approved	Approved	Approved	Approved

AVONITE® SHAPED ACRYLIC ELEMENTS COLLECTION

Aristech Surfaces LLC offers an extensive range of 12 sinks, 45 washbasins, 2 bathtubs and 4 shower trays for all types of commercial and residential use. These come in a range of shapes: oval, square, rectangular and curved. Featuring classic, timeless models for facilities with enduring style, the collection embodies simple, clean décor.



Certified leader:



LIVING
BUILDING
CHALLENGE

**NEW COLOURS, TRENDS AND EVENTS...
JOIN OUR COMMUNITY AND DISCOVER
NEW AND INSPIRING IDEAS EACH WEEK.**



**Global Headquarters
ARISTECH SURFACES LLC**

7350 Empire Drive
Florence KY 41042
USA

T +1 800-354-9858

info.europe@aristechsurfaces.com

Find your closest distributor on

WWW.ARISTECHSURFACES.COM/AVONITE



AVONITE® and ADVANC3® are registered trademarks of Aristech Surfaces LLC. All other trademarks and product names are trademarks or registered trademarks of their respective rights owners. The information contained in this brochure is intended to be for information only and can be amended at any time without prior notification © 2021 Aristech Surfaces LLC. All rights reserved.